

# Microwave Optics System

WA-9314C

## Microwave Accessory Package

WA-9315

# Complete Microwave Optics System

WA-9316A

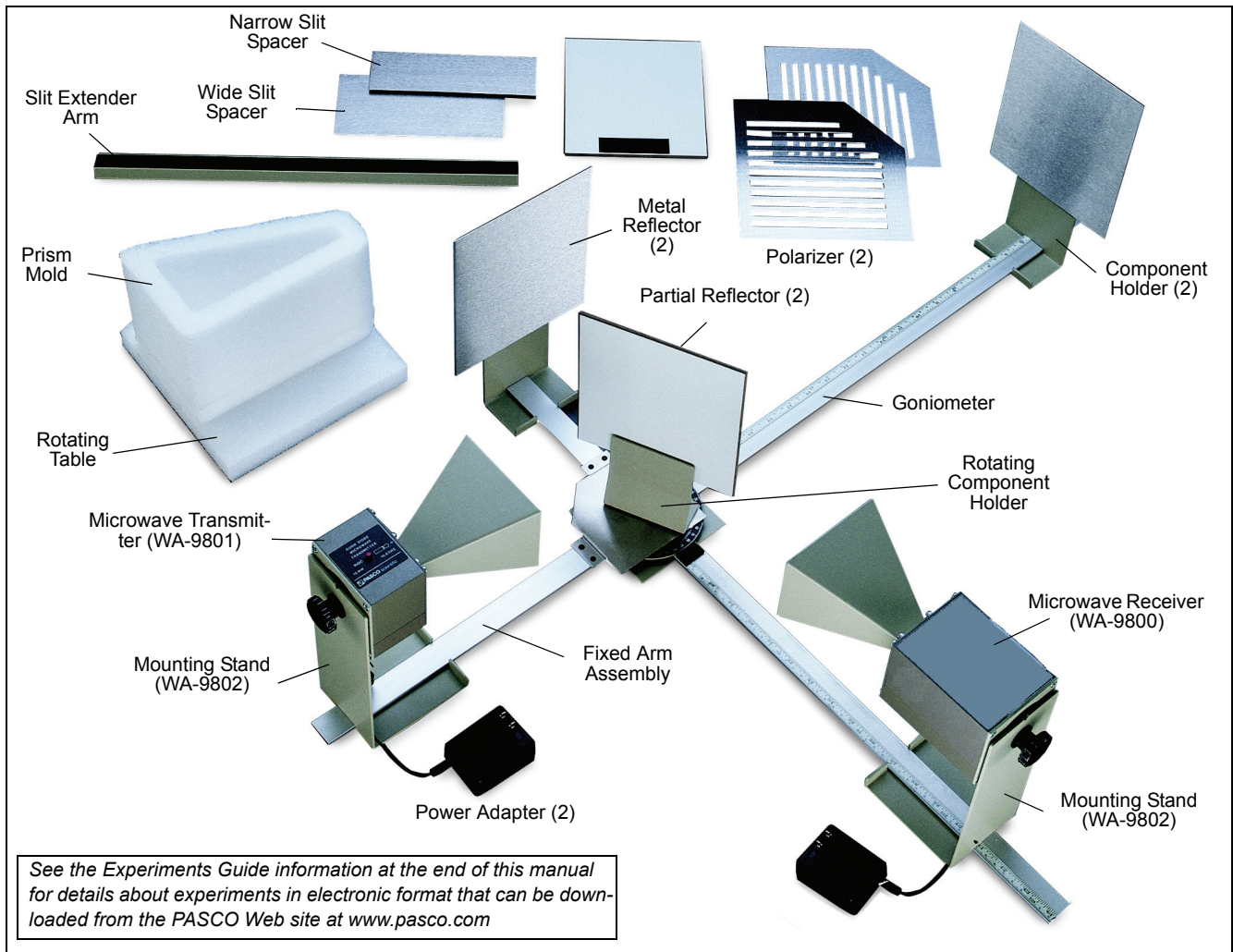

Model	Included Items
WA-9316A	Microwave Optics System (WA-9314C)
	Microwave Accessory Package (WA-9315)

Microwave Optics System (WA-9314C)	Microwave Optics System (WA-9314C)
Microwave Receiver WA-9800	Metal Reflectors (2)
Microwave Transmitter WA-9801	Partial Reflectors (2)
Mounting Stands (2) WA-9802	Polarizers (2)
Power Adapters (2)	Slit Extender Arm
Goniometer	Narrow Slit Spacer
Fixed Arm Assembly	Wide Slit Spacer
Rotating Table	Ethafoam Prism Mold
Component Holders (2)	Styrene Pellets, not shown
Rotating Component Holder	Tubular Plastic Bags (4), not shown

Microwave Accessory Package (WA-9315)
Cubic Lattice* (Bragg’s crystal model)
Polyethylene Panel

\*The Cubic Lattice contains 100 metal spheres in a 5 by 5 by 4 array.

Recommended Equipment
Microwave Detector Probe (WA-9319A)
PASCO Computer Interface
PASCO Data Acquisition Software
PASCO Voltage Sensor

**Important Note**

- CAUTION — Under some circumstances, microwaves can interfere with electronic medical devices. If you use a pacemaker, or other electronic medical device, check with your doctor or the manufacturer to be certain that low power microwaves at a frequency of 10.525 GHz will not interfere with its operation.

**FCC Compliance**

**FC** This device complies with Part 15 of the FCC Rules. Operation is subject to the following two conditions:

1. This device may not cause harmful interference.
2. This device must accept any interference received, including interferences that may cause undesired operation.

*Changes or modifications not expressly approved by PASCO scientific could void the user’s authority to operate the equipment.*

**Introduction**

There are many advantages to studying optical phenomena at microwave frequencies. Using a 2.85 centimeter microwave wavelength transforms the scale of the experiment. Microns become centimeters and variables obscured by the small scale of the tradition optics experiments are easily seen and manipulated. The PASCO Complete Microwave Optics System is designed to take full advantage of these educational benefits. The Complete Microwave Optics System consists of the Microwave Optics System and the Microwave Accessory Package. The Microwave Optics System comes with a 2.85 centimeter wavelength microwave transmitter and a receiver with variable amplification from 1X to 30X. All the accessory equipment needed to investigate a variety of wave phenomena is also included.

This manual describes the operation and maintenance of the microwave equipment and presents an overview of many experiments. These experiments range from quantitative investigation of reflection and refraction to microwave models of the Michelson and Fabry-Perot interferometers. Experiments for investigating Bragg diffraction and Brewster’s angle are included, but require the Microwave Accessory Package.

The experiment write-ups are available in electronic format for download from the PASCO Web site ([www.pasco.com](http://www.pasco.com)).

## Initial Setup

To attach the microwave Transmitter and Receiver to their respective stands prior to performing experiments, proceed as follows:

1. Remove the hand screw from the back panel of both the Transmitter and the Receiver.
2. Attach both units to the stands as shown. Observe the location of the washers. Put one washer on each side of the stand.

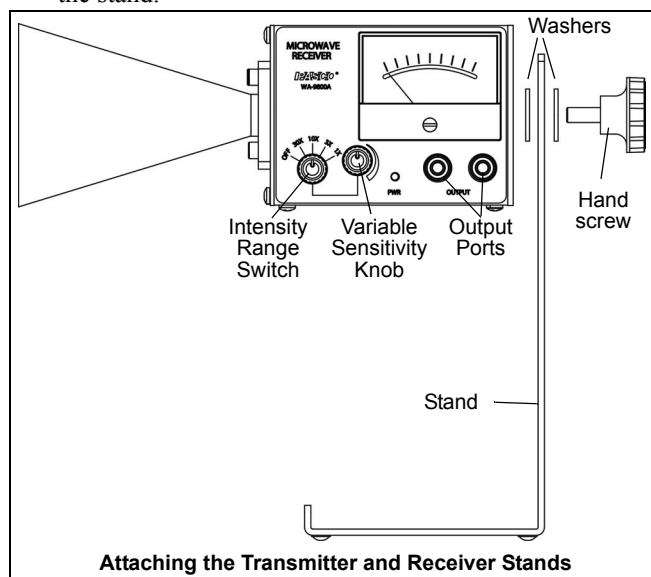

3. To adjust the polarization angle of the Transmitter or Receiver, loosen the hand screw, rotate the unit, and tighten the hand screw at the desired orientation. Notice the rotational degree label on the back of each unit for measuring the angle of polarization. Be aware, however, that since the Transmitter and Receiver face each other in most experiments it is important to match their polarization angle. If you rotate one unit to an angle of 10-degrees, you must rotate the other to -10-degrees (350-degrees) to achieve the proper polar alignment.

## Equipment

### Gunn Diode Microwave Transmitter

The Microwave Transmitter provides 15 milliwatts (mW) of coherent, linearly polarized microwave output at a wavelength of 2.85 cm. The unit consists of a Gunn diode in a 10.525 gigahertz (GHz) resonant cavity, a microwave horn to direct the output, and an 18 cm stand to help reduce table top reflections. The Transmitter is powered directly from a standard 115 or 220/240 volt (V) alternating current (AC), 50/60 Hz outlet by using the included power adapter. Other features are a light emitting diode (LED) power-ON indica-

tor and a rotational degree label on the back panel that allows easy measurement of the angle of polarization.

The Gunn diode acts as a non-linear resistor that oscillates in the microwave band. The output is linearly polarized along the axis of the diode and the attached horn radiates a strong beam of microwave radiation centered along the axis of the horn.

### To Operate the Microwave Transmitter

Plug the power adapter cord into the jack on the Transmitter's bottom panel (opposite the label) and plug the power adapter into a standard 115 or 220/240 VAC, 50/60 Hz outlet. The LED will light when the unit is on.

**CAUTION:** The output power of the Microwave Transmitter is well within standard safety levels. Nevertheless, never look directly into the microwave horn at close range when the Transmitter is on.

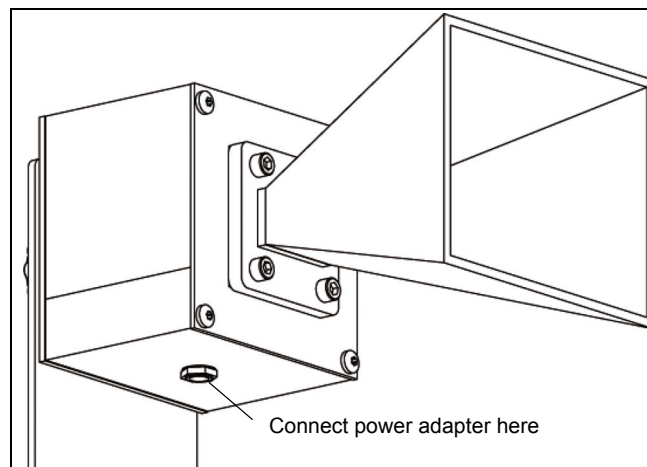

### Power Adapter Specifications:

9 volt DC, 500 milliampere (mA);

Miniature Phone Jack Connector (the tip is positive)

### Schottky Diode Microwave Receiver

The Microwave Receiver provides a meter reading that, for low amplitude signals, is approximately proportional to the intensity of the incident microwave signal. A microwave horn identical to that of the Transmitter's collects the microwave signal and channels it to a Schottky diode in a 10.525 GHz resonant cavity. The diode responds only to the component of a microwave signal that is polarized along the diode axis, producing a direct current (DC) voltage that varies with the magnitude of the microwave signal.

Special features of the Receiver include four amplification ranges—from one to thirty—with a variable sensitivity knob that allows fine tuning of the amplification in each range. For convenience in class demonstrations, banana plug connectors provide for an output signal to be sent to a projection voltmeter or a PASCO Computer Interface. This output can also be used for close examination of the signal using an oscilloscope. The receiver is powered from a standard 115 or 220/240 VAC, 50/60 Hz outlet by using the included power

adapter, and has an LED power-ON indicator. As with the Transmitter, an 18 cm high mount minimizes table top reflections, and a rotational degree label on the back panel allows convenient measurements of the polarization angle.

The connector labeled “EXTERNAL ANTENNA” on the side of the Receiver is for an optional Microwave Detector Probe (WA-9319A). Such a probe works the same as the Receiver except it has no horn or resonant cavity. The detector probe is particularly convenient for examining wave patterns in which the horn might get in the way

**NOTE:** The detector diode in the Receiver is a non-linear device. This non-linearity will provide no problem in most experiments. However, it is important to realize that the meter reading is not directly proportional to either the electric field (E) or the intensity (I) of the incident microwave. Instead, it generally reflects some intermediate value.

### To Operate The Microwave Receiver:

Start with the INTENSITY selection switch in the OFF position.

1. Plug the power adapter cord into the jack labeled “9VDC@500mA” on the Receiver’s side panel (opposite the label) and plug the power adapter into a standard 115 or 220/240 VAC, 50/60 Hz outlet. The “PWR” LED on the label side will light when the INTENSITY selection switch is turned from OFF to one of the amplification levels.
2. Turn the INTENSITY selection switch from OFF to 30X, the lowest amplification level. The power-ON indicator LED should light.

**NOTE:** The INTENSITY selection settings (30X, 10X, 3X, 1X) are the values you must multiply the meter reading by to normalize your measurements. The 30X selection, for example, means that you must multiply the meter reading by 30 to get the same value you would measure for the same signal with the INTENSITY selection set to 1X. Of course, this is true only if you do not change the position of the VARIABLE SENSITIVITY knob between measurements.

3. Point the microwave horn toward the incident microwave signal. Unless polarization effects are under investigation, adjust the polarization angles of the Transmitter and Receiver to the same orientation (e.g., both horns vertically, or both horns horizontally).
4. Adjust the VARIABLE SENSITIVITY knob to attain a meter reading near midscale. If no deflection of the meter occurs, increase the amplification by turning the INTENSITY selection switch clockwise. Remember, always multiply your meter reading by the appropriate INTENSITY selection (30X, 10X, 3X, or 1X) if you

want to make a quantitative comparison of measurements taken at different INTENSITY settings.

### Adjusting the Receiver

#### Meter mechanical zero adjustment:

1. Turn the INTENSITY switch to OFF.

The mechanical zero adjustment is located on the meter, centered just below the meter face.

2. With the meter level and in the horizontal position, use a small (1/8”) flat-blade screwdriver to adjust the meter needle to read as close to 0 as possible.

### Accessory Equipment

Accessory equipment for the Microwave Optics System includes the following:

#### Goniometer:

The Goniometer has a square metal base and two arms. The long arm is fixed. The other arm is free to rotate about the center of the base 43 cm long. Each arm has a magnetic strip on the underside and a metric scale on the top. On top of the base is a circular degree plate. Other accessories such as the Fixed Arm Assembly, the Rotating Table, or the Rotating Component Holder can be mounted on top of the center post of the degree plate.

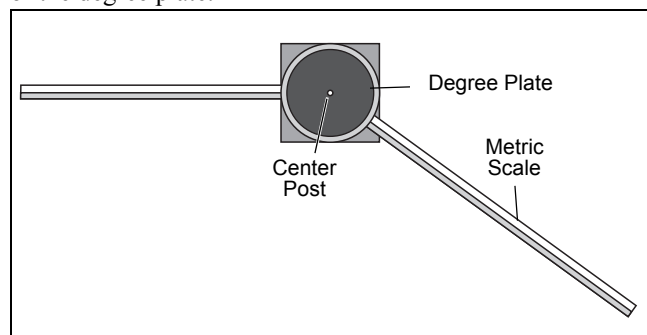

#### Fixed Arm Assembly:

The Fixed Arm Assembly has a pentagonal metal base and two arms. The base has a circular magnetic pad on its underside and a hole that fits over the center post of the Goniometer. Each arm has a magnetic strip on the underside and a metric scale on the top.

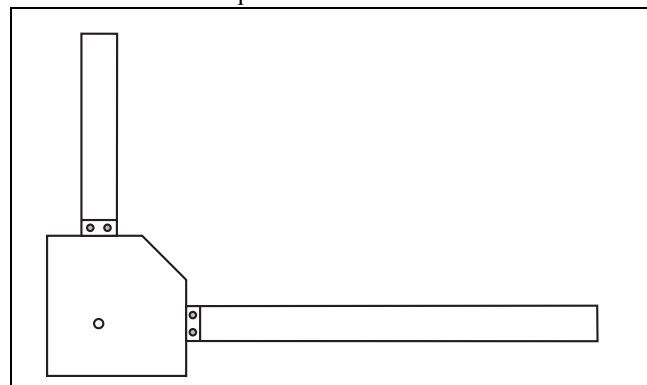

**Rotating Table:**

The Rotating Table has a circular metal base on top of a circular magnetic pad. Both have a hole in them that can fit on the center post of the Goniometer. The Rotating Table also has a pedestal and a square platform, both made of ethafoam.

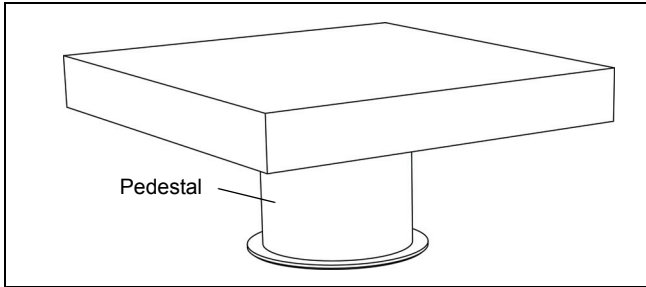

**Component Holders (2):**

The Component Holders have magnetic pads front and back at the top of the holder. They are designed to fit on the arms of the Goniometer or Fixed Arm Assembly.

**Rotating Component Holder:**

The Rotating Component Holder has a magnetic pad on one side of its upper part, and a hole in its base that fits over the center post of the Goniometer.

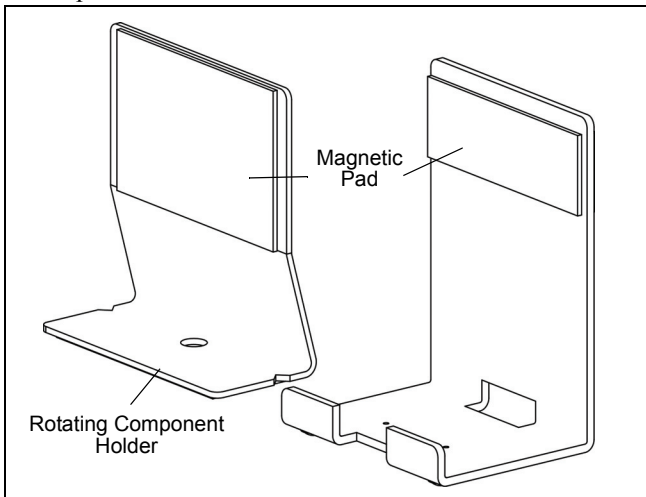

**Metal Reflectors (2):**

The Metal Reflectors are thin rectangular sheets of stainless steel that are 6 inches (12.2 cm) by 7 inches (17.7 cm). They can be mounted on the magnetic pads of the holders or the magnetic strip on the Slit Extender Arm.

**Partial Reflectors (2):**

The Partial Reflectors are rectangular pieces of a composite wood-like material (Masonite®) that have a stainless steel pad on the back and a white finish on the front. The steel pad allows the reflector to be mounted on the magnetic pads of

the holders. They are approximately the same length and width as the Metal Reflectors.

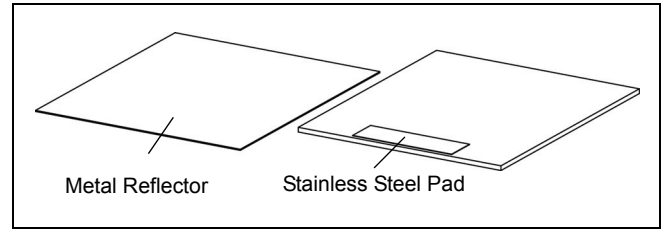

**Polarizers (2):**

The Polarizers are thin pentagonal sheets of stainless steel with eleven slots. The Polarizers can be mounted on the magnetic pads of the holders.

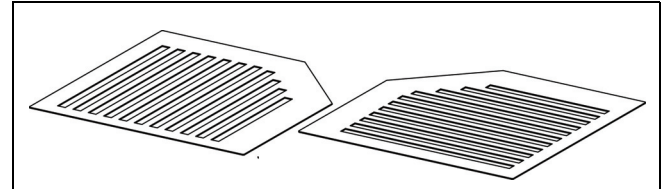

**Slit Extender Arm:**

The Slit Extender Arm is a piece of metal with a cross-section that is “L” shaped, and a magnetic strip on the back. It also has a small stainless steel pad on the front. The steel pad allows the arm to be mounted on the magnetic pads of the holders, and the reflectors and spacers can be mounted on the magnetic strip of the extender arm.

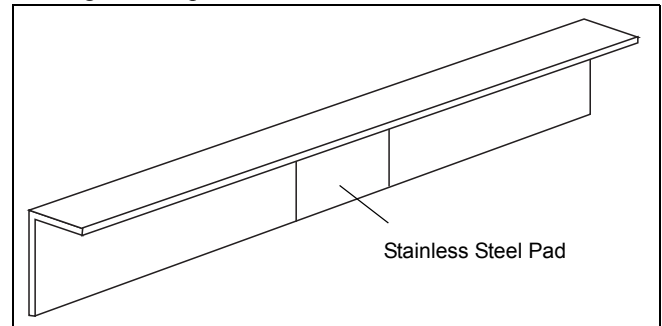

**Slit Spacers:**

The Narrow and Wide Slit Spacers are rectangular pieces of stainless steel designed to be used for diffraction experiments. The Narrow Slit Spacer is 2.375 inches (6 cm) by 6 inches (17.7 cm) and the Wide Slit Spacer is 3.5 inches (9 cm) by 6 inches (17.7 cm). The spacers can be mounted on the magnetic strip on the Slit Extender Arm or the magnetic pads on the holders.

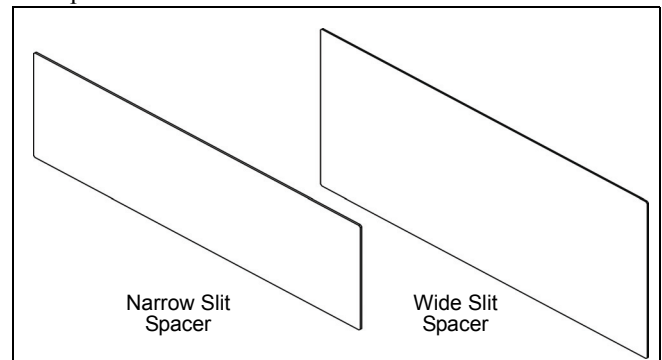

**Ethafoam Prism Mold:**

The Prism Mold has a triangular shape and is designed to be used for refraction experiments. It can be mounted on the Rotating Table so that it will be at the same height as the Transmitter and Receiver.

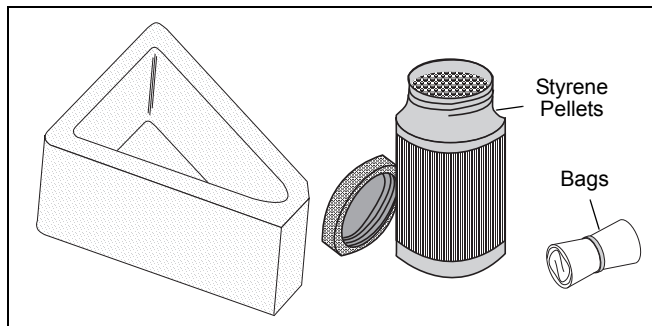

**Tubular Plastic Bags (4):**

The Tubular Plastic Bags are designed to be used for fiber optics experiments. A bag can be filled with Styrene Pellets and used as a “light pipe” to demonstrate internal reflection.

**Styrene Pellets:**

The Styrene Pellets can be used with the Prism Mold for refraction experiments and the Tubular Plastic Bags for fiber optics experiments.

**Microwave Accessory Package**

The WA-9315 Microwave Accessory Package (which is part of the Complete Microwave Optics System Model WA-9316A) includes the following:

**Cubic Lattice:**

The Cubic Lattice contains 100 steel spheres arranged in a 5 by 5 by 4 array to be used for Bragg’s crystal diffraction.

**Polyethylene Panel:**

The Polyethylene Panel is designed to be used for a Brewster’s Angle experiment.

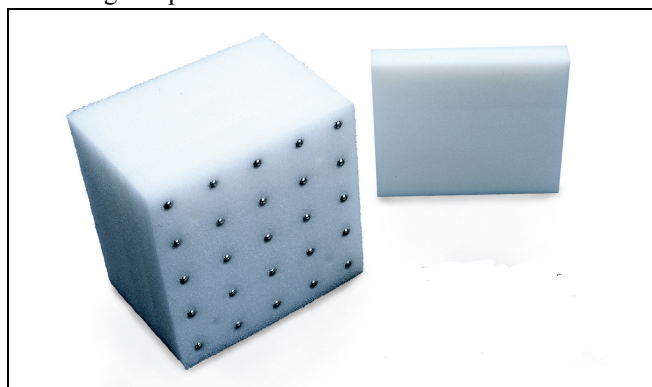

**Microwave Detector Probe (WA-9319A)**

The WA-9319A Microwave Detector Probe plugs directly into the port on the side of the Microwave Receiver labeled EXTERNAL ANTENNA. The probe is essential for experiments in which the horn of the Receiver might otherwise

interfere with the wave pattern being measured. The Probe is approximately 7.5 cm by 14.5 cm and can be mounted on the magnetic pad of a Component Holder.

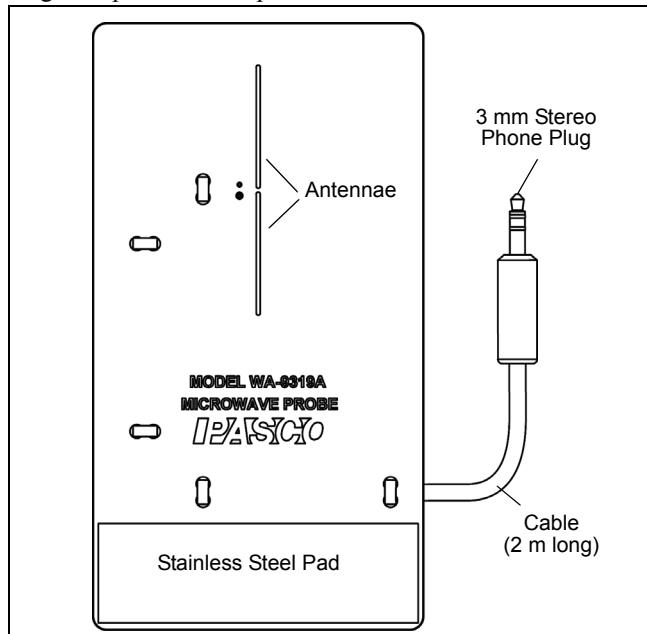

**Assembling Equipment for Experiments**

The arms of the Goniometer or the Fixed Arm Assembly slide through the holes in the Component Holders as shown. Make sure the magnetic strip on the bottom of the arm grips the base of the carriage. To adjust the position of the holders, just slide them along the arms. Attach the mounting stands of the microwave Transmitter and Receiver to the arms of the Goniometer or Fixed Arm Assembly in the same manner.

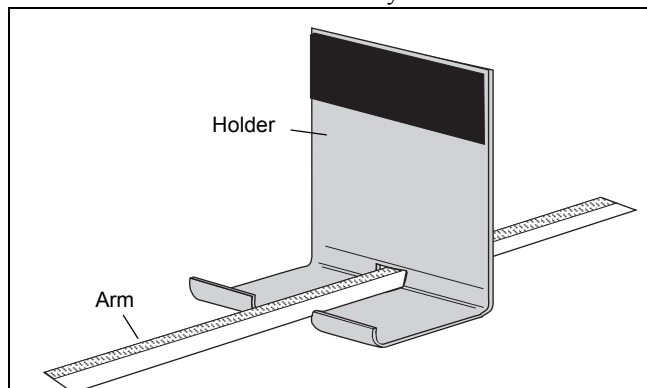

For most experiments it is advantageous to attach the Transmitter to the long arm of the Goniometer and the Receiver to the shorter, rotatable arm. This maintains a fixed relationship between the microwave beam and components mounted on the long arm (or on the degree plate) of the Goniometer. In turn the Receiver moves easily to sample the output.

Reflectors, Partial Reflectors, Polarizers, Slit Spacers, and the Slit Extender Arm all attach magnetically to the Component Holders. The metric scale along the Goniometer and Fixed Arm Assembly arms and the degree plate at the junction of the Goniometer arms allow easy measurement of component placement.

- It is recommended that the apparatus be mounted on a CLEAN, SMOOTH table.
- Before setting up the equipment, brush off any material—particularly metal chips—that might have adhered to the magnetic strips and magnetic pads.

## Maintenance

Regular maintenance for this equipment is minimal. When not in use, the equipment can be stored in the shipping box. Inspect the magnetic strips and magnetic pads and remove anything - especially bits of metal - that adhere to them.

If problems arise with the equipment DO NOT attempt to fix this equipment yourself. Contact PASCO scientific. (See the Technical Support information.)

## Experiment Guide

An Experiment Guide for the Microwave Optics System that is in electronic format (portable document format or PDF) is available to download from the PASCO web site at [www.pasco.com](http://www.pasco.com). At the PASCO web site, enter the product name (such as Microwave Optics) or the product number (WA-9314C) in the “Search” window.

The list of experiments in the Experiment Guide can be found at the end of this manual.

### Activity 1: Introduction to the Microwave Optics System

Activity 1 (see page 9) is an example of the worksheet style of the experiment write-ups.

## Technical Support

For assistance with any PASCO product, contact PASCO at:

Address: PASCO scientific  
10101 Foothills Blvd.  
Roseville, CA 95747-7100

Phone: +1 916 786 3800 (worldwide)  
800-772-8700 (U.S.)

E-mail: [support@pasco.com](mailto:support@pasco.com)

Web [www.pasco.com](http://www.pasco.com)

For the latest information about the Complete Microwave Optics System or its accessories,

go to the PASCO web site at [www.pasco.com](http://www.pasco.com) and enter the model number or the product name in the search window.

**Limited Warranty** For a description of the product warranty, see the PASCO catalog. **Copyright** The PASCO scientific *Instruction Manual* is copyrighted with all rights reserved. Permission is granted to non-profit educational institutions for reproduction of any part of this manual, providing the reproductions are used only in their laboratories and classrooms, and are not sold for profit. Reproduction under any other circumstances, without the written consent of PASCO scientific, is prohibited. **Trademarks** PASCO, PASCO Capstone, PASPORT, SPARK Science Learning System, SPARK SLS, and SPARKvue are trademarks or registered trademarks of PASCO scientific, in the United States and/or in other countries. For more information visit [www.pasco.com/legal](http://www.pasco.com/legal).

### Product End of Life Disposal Instructions:

This electronic product is subject to disposal and recycling regulations that vary by country and region. It is your responsibility to recycle your electronic equipment per your local environmental laws and regulations to ensure that it will be recycled in a manner that protects human health and the environment. To find out where you can drop off your waste equipment for recycling, please contact your local waste recycle/disposal service, or the place where you purchased the product.

The European Union WEEE (Waste Electronic and Electrical Equipment) symbol (to the right) and on the product or its packaging indicates that this product must not be disposed of in a standard waste container.







# Activity: Introduction to the Microwave Optics System

## Equipment Needed:

Item	Item
Transmitter	Goniometer
Receiver	Reflector

## Purpose

This activity gives an introduction to the Microwave Optics System which may prove helpful in learning to use the equipment effectively and in understanding the significance of measurements made with this equipment.

## Procedure

1. Arrange the Transmitter and Receiver on the Goniometer as shown in Figure 1 with the Transmitter attached to the fixed arm. Be sure to adjust both Transmitter and Receiver to the same polarity — the horns should have the same orientation, as shown.
2. Plug in the Transmitter and the Receiver. Turn the INTENSITY selection switch on the Receiver from OFF to 10X. (The LEDs should light up on both units.)

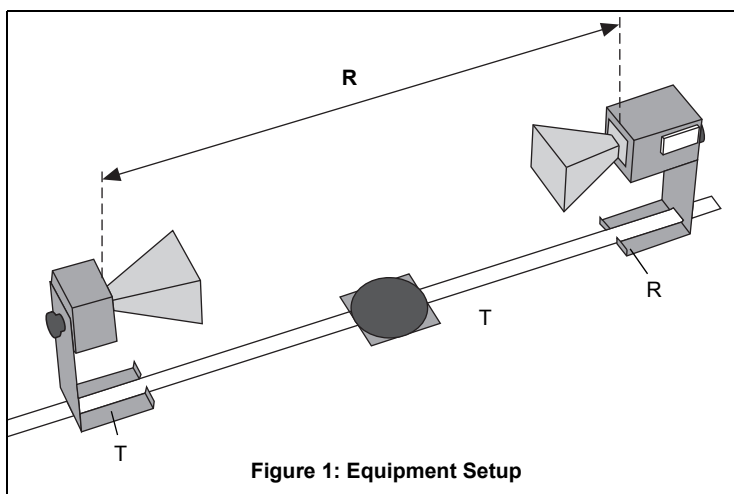

Figure 1: Equipment Setup

3. Adjust the Transmitter and Receiver so the distance between the source diode in the Transmitter and the detector diode in the Receiver (the distance labeled **R** in Figure 1) is 40 cm (see Figure 2 for location of points of transmission and reception). The diodes are at the locations directly above the points marked “T” and “R” on the stands. Adjust the INTENSITY and VARIABLE SENSITIVITY knobs on the Receiver so that the meter reads 1.0 (full scale).

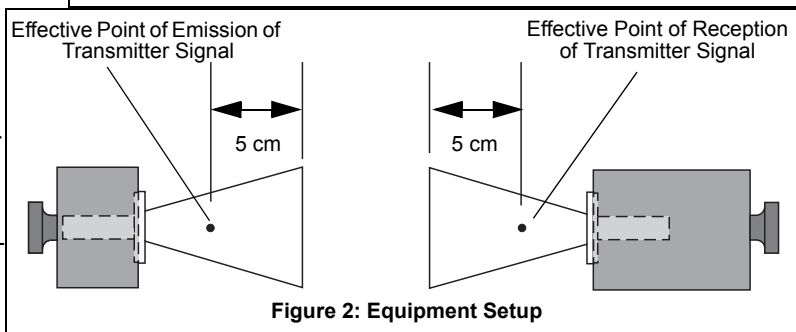

Figure 2: Equipment Setup

4. Set the distance **R** to each of the values shown in Table 1. Record the meter reading for each value of **R**. (Do not adjust the Receiver controls between measurements.) After making the measurements, perform the calculations shown in the table.

Table 1: Data

R (cm)	Meter Reading (M)	M X R (cm)	M X R <sup>2</sup> (cm <sup>2</sup> )
40			
50			
60			
70			
80			
90			
100			

- Set **R** to some value between 70 and 90 cm. While watching the meter, slowly decrease the distance between the Transmitter and Receiver. Does the meter deflection increase steadily as the distance decreases?
- Set **R** to between 50 and 90 cm. Move a Reflector, its plane parallel to the axis of the microwave beam, toward and away from the beam axis, as shown in Figure 3. Observe the meter readings. Can you explain your observations in steps 5 and 6? (Don't worry if you can't; you will have a chance to investigate these phenomena more closely in other experiments.) For now just be aware of the following:

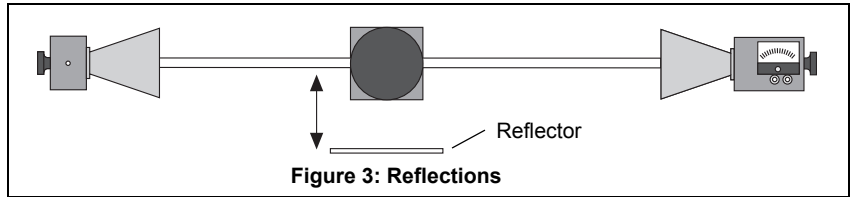

**IMPORTANT:** Reflections from nearby objects, including the table top, can affect the results of your microwave experiments. To reduce the effects of extraneous reflections, keep your experiment table clear of all objects, especially metal objects, other than those components required for the current experiment.

- Loosen the hand screw on the back of the Receiver and rotate the Receiver as shown in Figure 4. This varies the polarity of maximum detection. (Look into the receiver horn and notice the alignment of the detector diode.) Observe the meter readings through a full 360 degree rotation of the horn. A small mirror may be helpful to view the meter reading as the receiver is turned. At what polarity does the Receiver detect no signal?

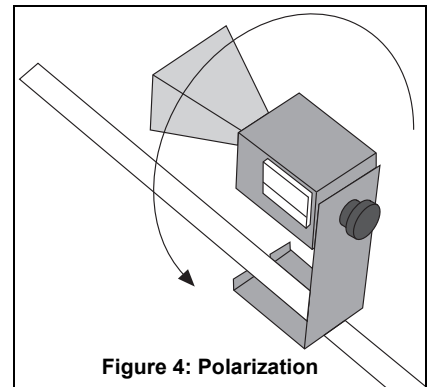

NOTE: Try rotating the Transmitter horn as well. When finished, reset the Transmitter and Receiver so their polarities match (e.g., both horns are horizontal or both horns are vertical).

- Position the Transmitter so the output surface of the horn is centered directly over the center of the Degree Plate of the Goniometer arm (see Figure 5). With the Receiver directly facing the Transmitter and as far back on the Goniometer arm as possible, adjust the Receiver controls for a meter reading of 1.0. Then rotate the rotatable arm of the Goniometer as shown in the figure. Set the angle of rotation (measured relative to the 180-degree point on the degree scale) to each of the values shown in Table 2, and record the meter reading at each setting

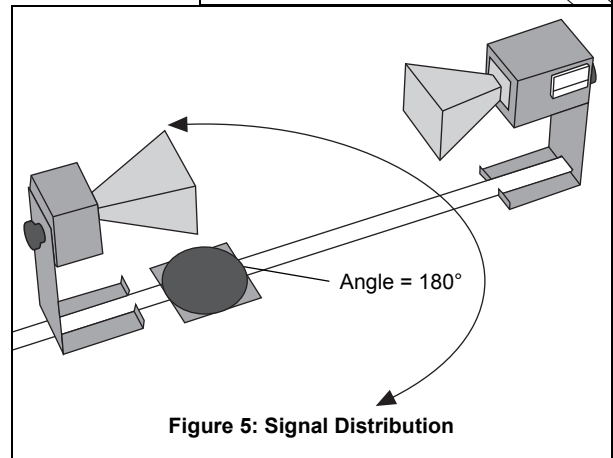

Table 2: Data

Angle of Receiver	Meter Reading	Angle of Receiver	Meter Reading	Angle of Receiver	Meter Reading
90°		160		230	
100		170		240	
110		180		250	
120		190		260	
130		200		270	
140		210			
150		220			

**Questions**

1. The electric field of an electromagnetic wave is inversely proportional to the distance from the wave source, (i.e.,  $E = 1/R$ ). Use your data from step 4 of the experiment to determine if the meter reading of the Receiver is directly proportional to the electric field of the wave.
  2. The intensity of an electromagnetic wave is inversely proportional to the square of the distance from the wave source (i.e.,  $I = 1/R^2$ ). Use your data from step 4 of the experiment to determine if the meter reading of the Receiver is directly proportional to the intensity of the wave.
  3. Considering your results in step 7, to what extent can the Transmitter output be considered a spherical wave? A plane wave?
- (See the Teacher's Guide on the next page for typical results and answers to the questions.)